

Readout chips for X-ray flat panels

ams.com/ct-and-digital-x-ray



The AS585x Family – Readout ICs for X-ray digital flat panels

- Best-in-class figure of merit for speed, noise and power consumption
- High degree of flexibility
- Suitable for static, dynamic and ultra-fast applications
- Available in different chip-on-flex packaging designs

Sensing
is life.

General Description

The AS585x ICs are 16-bit, 256-channel low-noise charge-to-digital converters designed for use in digital X-ray systems. The high degree of programmability enables system performance optimization in a wide range of applications. The combination of fast speed, low noise and low power consumption maximizes the image quality and minimizes patient dose exposure whilst improving the time to market. Each channel front-end consists of a charge sensitive amplifier (CSA) and a correlated double sampler (CDS), that removes offset and flicker noise from the signal, which is then converted to digital. A fast and reliable LVDS interface transmits the output digital data off-chip. Built-in diagnostic functionalities enable error detection in the signal chain. Voltage references and a temperature sensor are included on the chip.

An SPI interface allows for easy programming of the device parameters. Four different power modes allow the user to minimize the current consumption for the chosen speed. Line times of 20, 28.5, 40 and 80 μs require as little as 3.1, 2.6, 1.6 and 1.1 mW per channel respectively. A special ADC operation mode decreasing the minimum line time to 15 μs without increasing the power consumption is also available. Additionally, it is possible to add together the charges in pairs of adjacent channels; with this binning, the fastest achievable line time is 10 μs . ams provides the AS585x series readout ICs in two different packaging options (the A- or B-type flex) and can supply other customer-specific flex designs on request.

Features

- 256 channels with 16-bit resolution
- Line times down to 20 μs (or 15 μs in ADC low-OSR mode)
- Binning mode (half number of effective channels) for 2x faster readout speed
- Binning and special 240-channels mode to enable 256, 240, 128 or 120 channels
- Supports detectors with line capacitance up to 200 pF
- Programmable settings: input charge range, holes or electrons polarity, detector timing, low-pass filter time constant and line time
- Up to three different internal charge pump cycles for offset adjusting, signal emulation and switch charge injection compensation
- Four power modes in addition to sleep and full power-down modes
- Correlated double sampling for offset subtraction with programmable time constant
- Built-in self-test features

Applications

- Static and dynamic digital X-rays
- Digital radiography
- Mammography
- Fluoroscopy
- Interventional X-ray imaging
- Industrial non-destructive testing

Benefits

- Flexible programming to optimize for application needs
- Suitable for a wide range of detector sizes
- Best-in-class combination of noise, power consumption and speed
- Ultra-low power for portable applications
- High-speed for dynamic applications
- Low-noise for great image quality
- Accurate temperature feedback
- Chip-on-flex packaging for immediate integration into the detector

AS585x Block Diagram

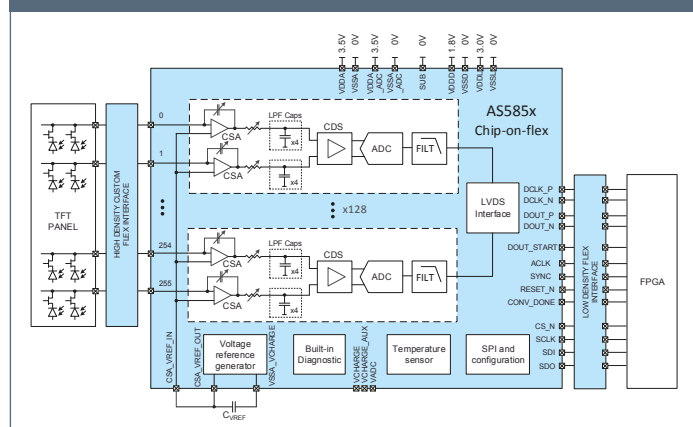

ams.com
 sensors@ams.com
 © 03/2021 by ams
 Subject to change without notice

Headquarters
 ams AG
 Tobelbader Strasse 30, 8141 Premstaetten, Austria
 Phone +43 3136 500-0



Sales Offices Worldwide
 sales-europe@ams.com
 sales-asia@ams.com
 sales-americas@ams.com