



Datasheet

DS000618

BELICE-850

Dot-Pattern Infrared Illuminator for 3D Stereoscopic Imaging

v1-00 • 2018-Nov-02

Abstract

The BELICE infrared illuminator is the most compact dot-projector for stereoscopic imaging available today. It produces a very high-contrast dot pattern that stereo-matching algorithms can use to mitigate the problem of lack of texture, and to produce high-accuracy depth maps.

BELICE enables active stereoscopic imaging to be implemented on a variety of platforms, from robotics to mobile devices.

Content Guide

1	General Description..... 3	9	Packing Information 17
1.1	Key Benefits & Features 3	9.1	Overview 17
1.2	Applications 3	9.2	Tray Label 17
1.3	Block Diagram 4	10	Soldering & Storage Information 18
2	Ordering Information..... 5	11	Handling..... 19
3	Pin Assignment 6	11.1	Pick Up..... 19
3.1	Pin Diagram..... 6	12	Appendix 20
3.2	Pin Description 6	12.1	RoHS & REACH Compliance 20
4	Absolute Maximum Ratings 7	12.2	Safety Advice 20
5	Belice Specification 8	13	Revision Information..... 21
6	Electrical Characteristics 10	14	Legal Information 22
6.1	Typical Operating Characteristics 11		
6.2	Imaging Setup 12		
6.3	Hotspot Detection..... 12		
7	Mechanical Drawings 13		
8	Application Information 15		
8.1	PCB Pad Layout and Solder Mask Recommendation 15		
8.2	Orientation of the Field of Illumination 15		

1 General Description

1.1 Key Benefits & Features

Stereoscopic imaging systems, however, often suffer from impaired performance when the scene lacks features: an example is a flat, smooth surface such as a wall. In such cases, the 3D information captured by stereoscopic imaging systems is typically incomplete or inaccurate. Furthermore, the search for features in the images often results in high computational loading.

Now ams has developed a unique, proprietary solution to this problem. The BELICE infrared illuminator, the most compact dot-projector for stereoscopic imaging available today, produces a very high-contrast dot pattern that stereo-matching algorithms can use to mitigate the problem of lack of texture, and to produce high-accuracy depth maps. The presence of the infrared pattern also reduces considerably the computational load imposed by the software, as it offers many features to facilitate matching of the left and right images.

BELICE enables active stereoscopic imaging to be implemented on a variety of platforms, from robotics to mobile devices.

The benefits and features of BELICE-850, Dot-Pattern Infrared Illuminator for 3D Stereoscopic Imaging, are listed below:

Figure 1:
Added Value of Using BELICE-850

Benefits	Features
Small package size	3.4mm x 3.5mm x 3.56mm
Module height compatible with integration in mobile platforms	3.56mm ± 0.1
Power efficient	High optical efficiency, high VCSEL efficiency
Easy component mounting	Standard lead-free solder reflow compatible
High contrast dot pattern	Optimized for active stereo vision

1.2 Applications

- Active stereo 3D sensors
- Integrated mobile 3D sensors
- Integrated tablets and all-in-one 3D sensors
- Front-facing and world-facing 3D cameras

1.3 Block Diagram

The functional blocks of this device are shown below:

Figure 2 :
Functional Blocks of BELICE-850

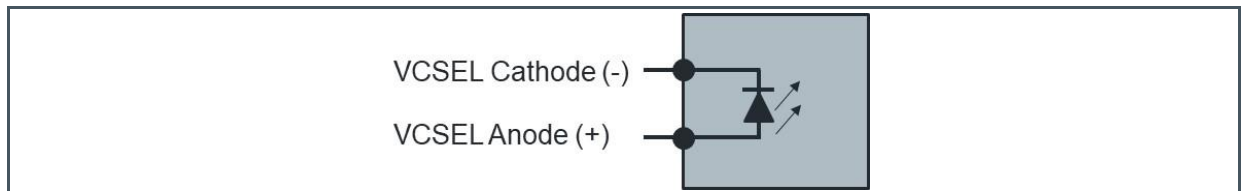

2 Ordering Information

Ordering Code	Description	Delivery Form	Delivery Quantity
APDE-00	Emitter type A with 5° pattern rotation / SMT contacted	Tray	143 pcs/tray
APDB-00	Emitter type B with 15° pattern rotation / SMT contacted	Tray	143 pcs/tray

3 Pin Assignment

3.1 Pin Diagram

Figure 3:
Module Bottom View

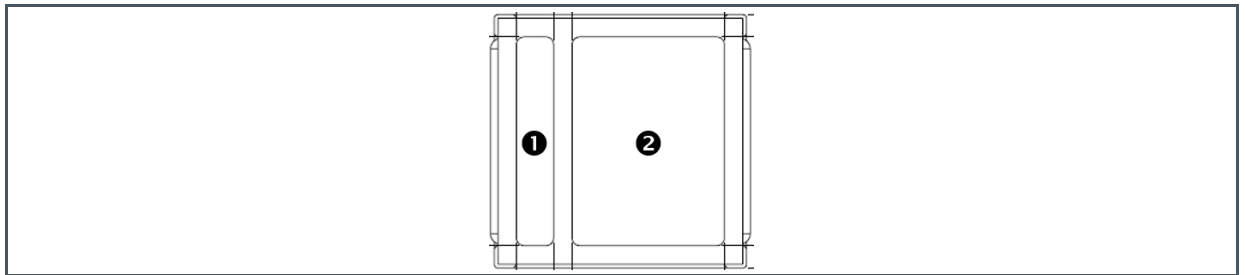

3.2 Pin Description

Figure 4:
Pin Description of BELICE-850

Pin Number	Pin Name	Description
1	Anode	VCSEL Power
2	Cathode	VCSEL Power

4 Absolute Maximum Ratings

Stresses beyond those listed under “Absolute Maximum Ratings” may cause permanent damage to the device. These are stress ratings only. Functional operation of the device at these or any other conditions beyond those indicated under “Operating Conditions” is not implied. Exposure to absolute maximum rating conditions for extended periods may affect device reliability.

Figure 5
Absolute Maximum Ratings of BELICE-850

Symbol	Parameter	Min	Max	Unit	Comments
Electrical Parameters					
V_F	Forward Voltage		3	V	25°C, Pulse >10nsec
I_F	Forward Current		7	A	25°C, Pulse >10nsec
I_{rev}	Reverse current)		10	μ A	25°C instantaneous
Continuous Power Dissipation ($T_{Case} = 70\text{ }^\circ\text{C}$)					
P_T	Continuous Power Dissipation		1000	mW	input power
Temperature Ranges and Storage Conditions					
T_{STRG}	Storage Temperature Range	- 40	80	$^\circ\text{C}$	
T_{Op}	Operating Temperature	0	80	$^\circ\text{C}$	IPC/JEDEC J-STD-020
MSL	Moisture Sensitivity Level		3		JESD22-A113D

5 Belice Specification

Figure 6:
Individual Emitter Characteristics

Parameter	Condition	Min	Typ	Max	Unit
Horizontal FOI 50% (deg)	Full width half max.		71		deg
Vertical FOI 50% (deg)	Full width half max.		51		deg
Number of dots	@ Camera FOV 68°x48°	5500	5700	5900	Dots
Contrast ⁽¹⁾		10	13		
Wavelength	@ 350mA, 25°C	842	850	848	nm
Spectral width	Full width half max @ 350mA, 25°C	0	1.5	3	nm
Wavelength shift with temperature			0.065	0.075	nm/°C
Thermal resistance	@ 100% duty cycle		26		K/W
Operating temperature	Heat sink temperature	10		60	°C
Storage temperature		-40		85	°C

(1) Contrast is defined for a single emitter grid, as the ratio of the 95th percentile of the dot intensity over the median intensity of the background.

Figure 7:
Other General Characteristics (pair of emitters)

Parameter	Value
Light Source	VCSEL
Pattern Rotation Each element of a BELICE pair	Type A (5°) ±1.5° (testing value) Type B (15°) ±1.5° (testing value)
Dimensions (X Y Z) (mm3) (Single emitter)	Type A/B 3.5 x 3.4 x 3.56
Electrical contacts	Type A/B Anode and cathode on backside
Number of electrical contacts	1x cathode and 1x anode
Assembly type	Reflow compatible

6 Electrical Characteristics

All limits are guaranteed. The parameters with Min and Max values are guaranteed with production tests or SQC (Statistical Quality Control) methods.

Figure 8:
Electrical Characteristics of BELICE-850

Symbol	Parameter	Conditions ⁽¹⁾	Min	Typ	Max	Unit
I_{op}	Operating current	Entire temp. range, CW		350		mA
P_{op}	Operating power	At RT, CW	200	250	280	mW
V_{op}	Operating voltage	Entire temp. range, CW	1.6	1.9	2.3	V
PCE_{op}	Operating PCE	Entire temp. range, CW	28	37		%
Duty cycle	PWM control			5	100	%
t_{rise}	Rise time				10	ns
I_{th}	Threshold current	At RT, CW	60	88	130	mA

- (1) Specified temperatures refer to the emitter case temperature (the emitter is mounted on a temperature-controlled stage); RT stands for Room Temperature (25°C)

6.1 Typical Operating Characteristics

Figure 9 :
Electro-Optical Performance

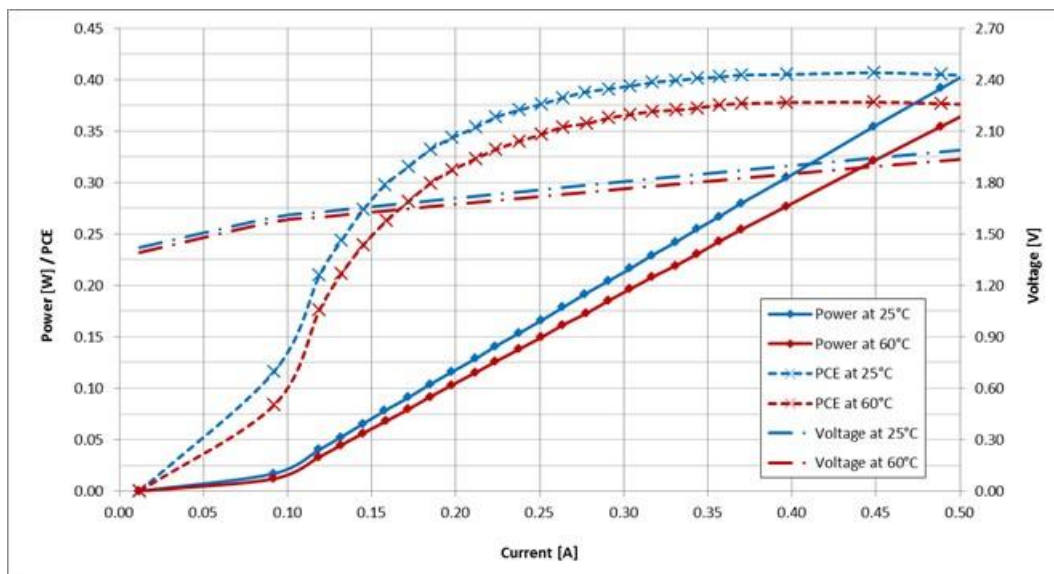

- (1) Typical Light - Current – Voltage and PCE (Power Conversion Efficiency) Characteristics of single BELICE configuration versus temperature. Measured at continuous operation, mounted on Cu block.

Figure 10:
Projected Dot Pattern

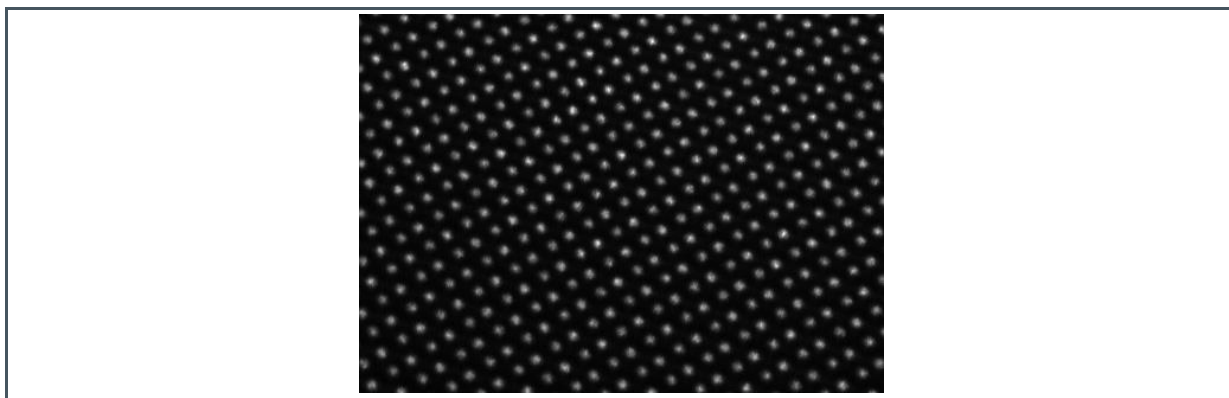

- (1) Projected dots pattern measured from BELICE (cropped image showing the central portion of the FOI)

6.2 Imaging Setup

For the pattern characterization, the output is projected onto a white, matte-finished target board (Lambertian surface), at a distance. Images are taken inside a dark chamber with a monochrome CCD camera and a wide angle objective.

6.3 Hotspot Detection

Every individual BELICE emitter is inspected during production to detect the presence of hotspots and similar non-uniformities that cause excessive brightness of the infrared pattern and could be harmful to the human eye.

7 Mechanical Drawings

Figure 11:
Package Dimensions

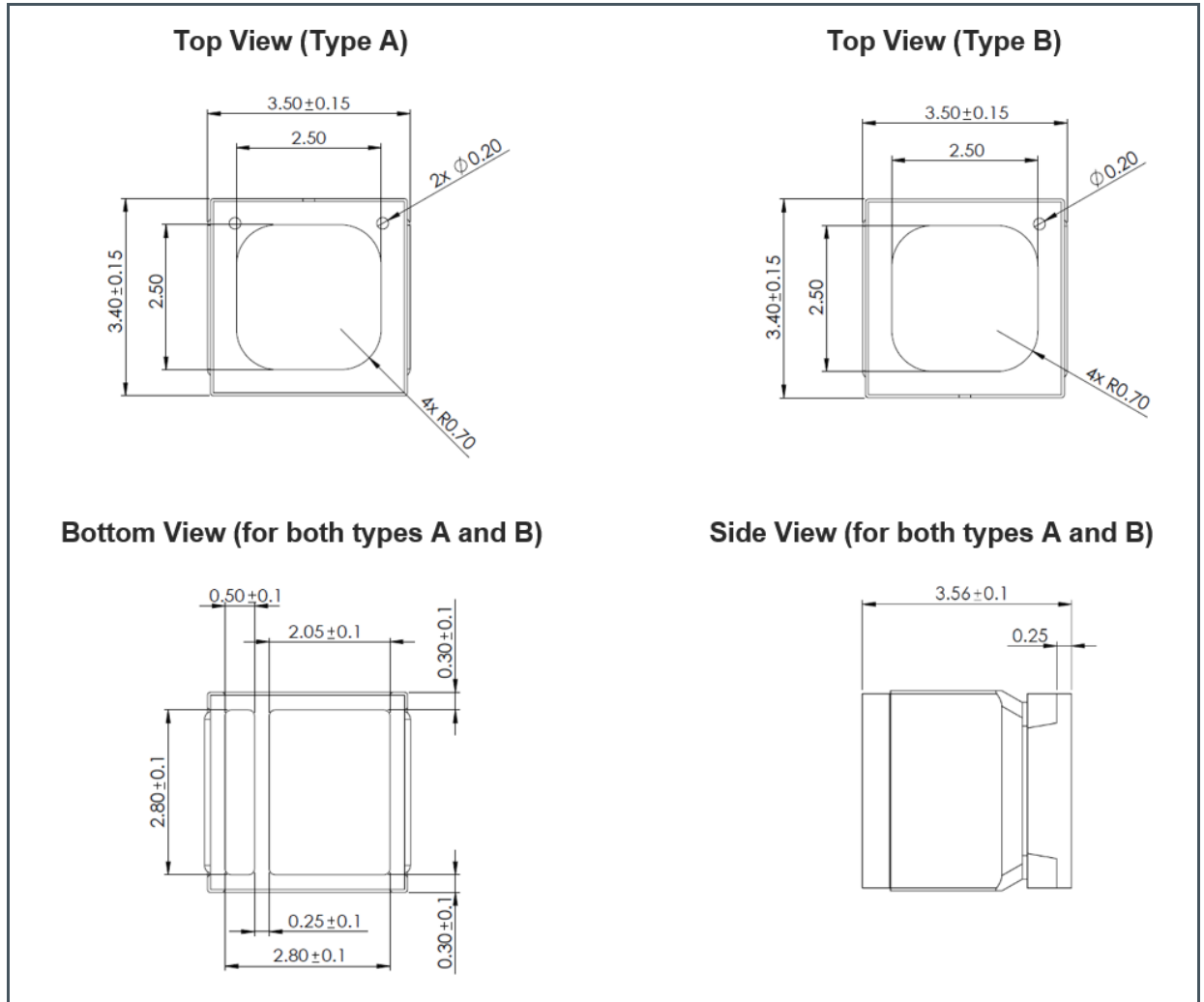

- (1) Outline dimensions of individual BELICE emitters Type A and B
- (2) All dimensions in mm

Figure 12:
3D View

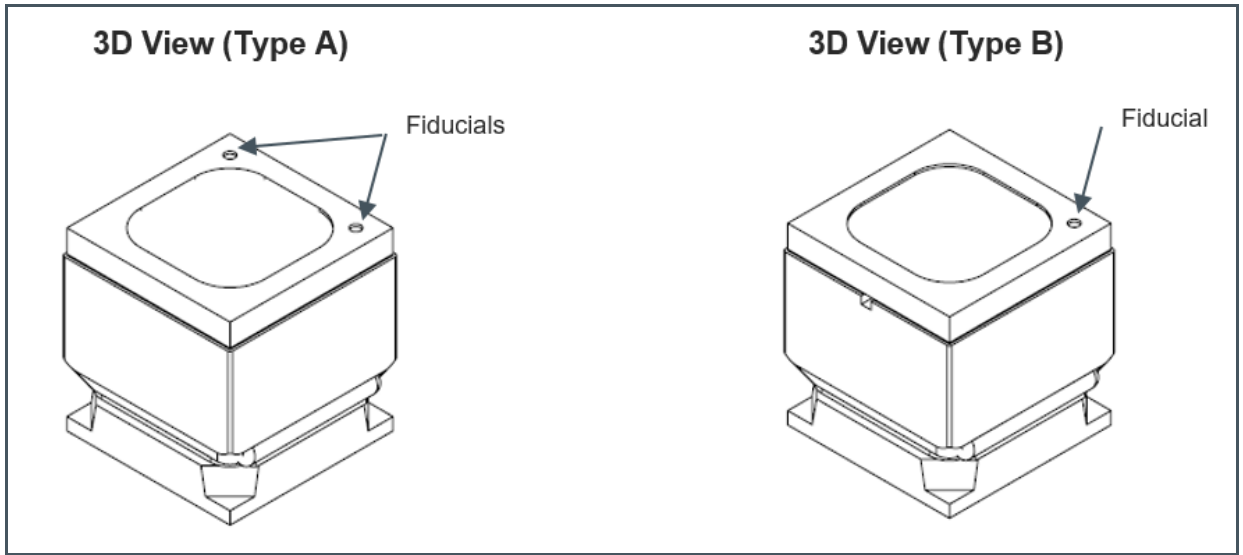

- (1) 3D view with Fiducials for distinguishing between type A and B

Figure 13:
Optical Aperture

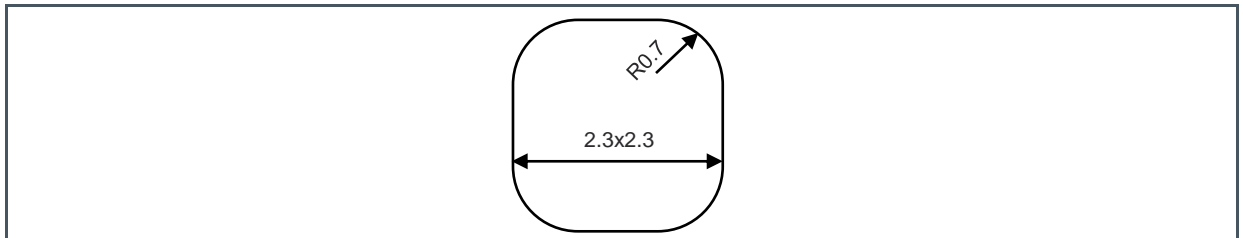

- (1) Optical aperture dimensions (defining the opening where the light is emitted through)
- (2) All dimensions in mm

8 Application Information

8.1 PCB Pad Layout and Solder Mask Recommendation

The drawings below are showing a recommendation for pad layouts and solder mask. This is only to be used as guide and not to be considered as a firm specification.

Figure 14:
Solder Mask Layout Type A/B

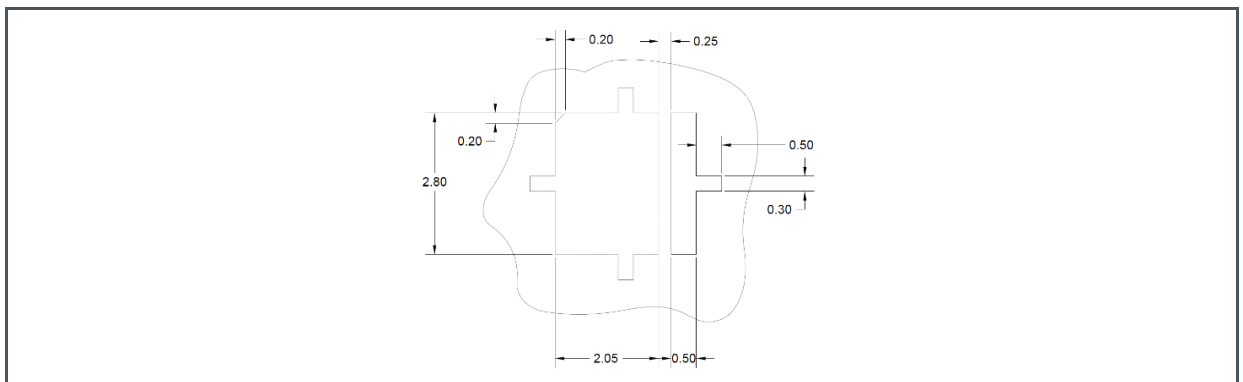

(1) All dimensions in mm

8.2 Orientation of the Field of Illumination

Figure 15:
FOI Orientation

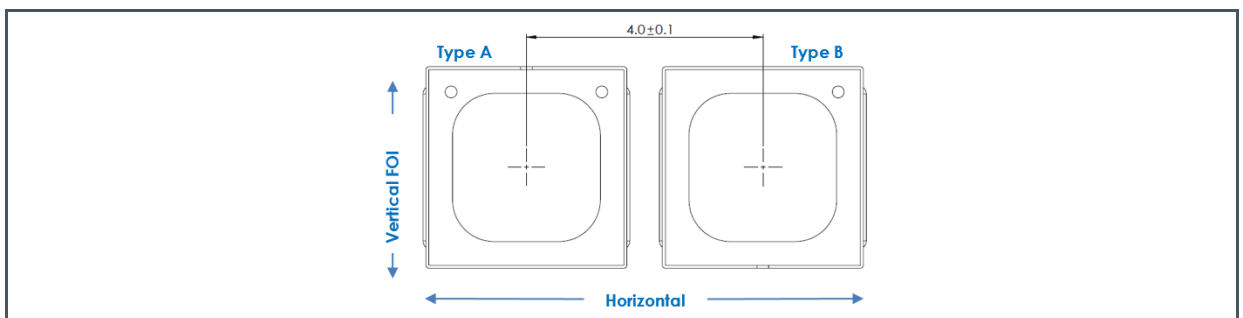

(1) Orientation of the Field of Illumination with respect to the BELICE emitter pair (the Horizontal direction of the FOI is to be aligned to the stereo camera pair axis). Recommended assembly of the two emitters forming BELICE (top view). One emitter is Type A, the other Type B. Note that the recommended nominal spacing between the two emitter lens centers is $4\text{mm} \pm 0.1$

Figure 16:
Alignment of BELICE-850 Modules

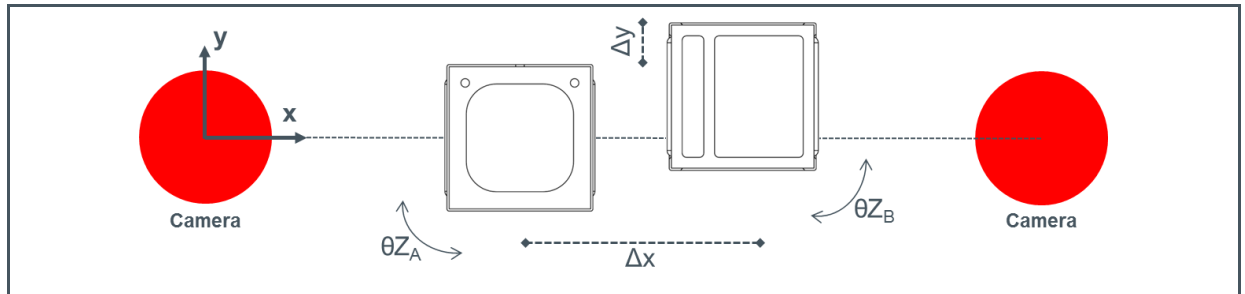

Figure 17:
Alignment Requirements for BELICE-850

Parameter	Tolerance	Conditions	Unit
Δx	Not critical		mm
Δy	Not critical		mm
Δz	Not critical		mm
Θx	Not critical		deg
Θy	Not critical		deg
Θz Top	$\pm 2^\circ$	When aligned to Top side fiducials ⁽³⁾ (emitting aperture) (Recommended)	deg
Θz Bottom	$\pm 0.85^\circ$	When aligned to Bottom side fiducials ⁽³⁾ (edges of anode and cathode Cu pad)	deg

- (1) Orientation of the Field of Illumination with respect to the BELICE emitter pair (the Horizontal direction of the FoI is to be aligned to the stereo camera pair axis). Recommended assembly of the two emitters forming BELICE (top view). One emitter is Type A, the other Type B. Note that the recommended nominal spacing between the two emitter lens centers is $4\text{mm} \pm 0.1$
- (2) After assembly, the rotation (Θz) of the BELICE module with respect to the horizontal axis of the stereo camera pair should be within the tolerance in the above table.
- (3) Do not use the outer module outline as reference for alignment. Use the features mentioned in the table
- (4) Fiducials to be referred to:
 - Top Side: round dots which are used to differentiate between type A and B, the baffle opening or the Cr aperture.
 - Bottom Side: Lead frame edges of anode and cathode Cu pad.

9 Packing Information

9.1 Overview

Sampling Shipments: The modules are shipped in trays (Material: PS Natural, 0.8mm).
 MP Shipping: The modules are shipped in JEDEC trays

Figure 18:
Shipping Tray Type A and B Dimensions and Overview

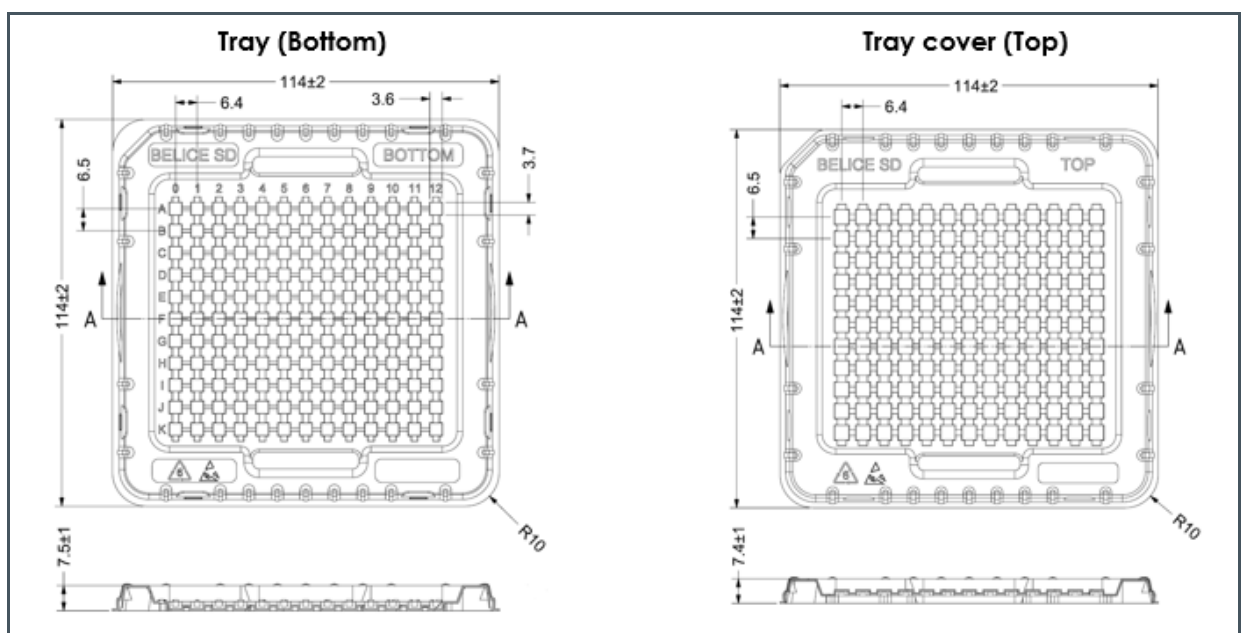

9.2 Tray Label

Trays are individually labeled. The label information is as follows:

- Part number (XXXX-XX) & Type A/B
- Tray ID
- Quantity
- Shipment Date
- Manufacturing country

The underlined items are included in the bar code

10 Soldering & Storage Information

BELICE modules have been tested for lead-free solder reflow compatibility with peak temperatures up to 250°C (MSL3).

An example reflow profile is provided in Figure 19. The exact reflow profile may depend on exact solder used.

An example of solder paste that can be used is Tamura LFSOLDER TLF-204-NH(20-38).

Figure 19:
Solder Reflow Profile Graph

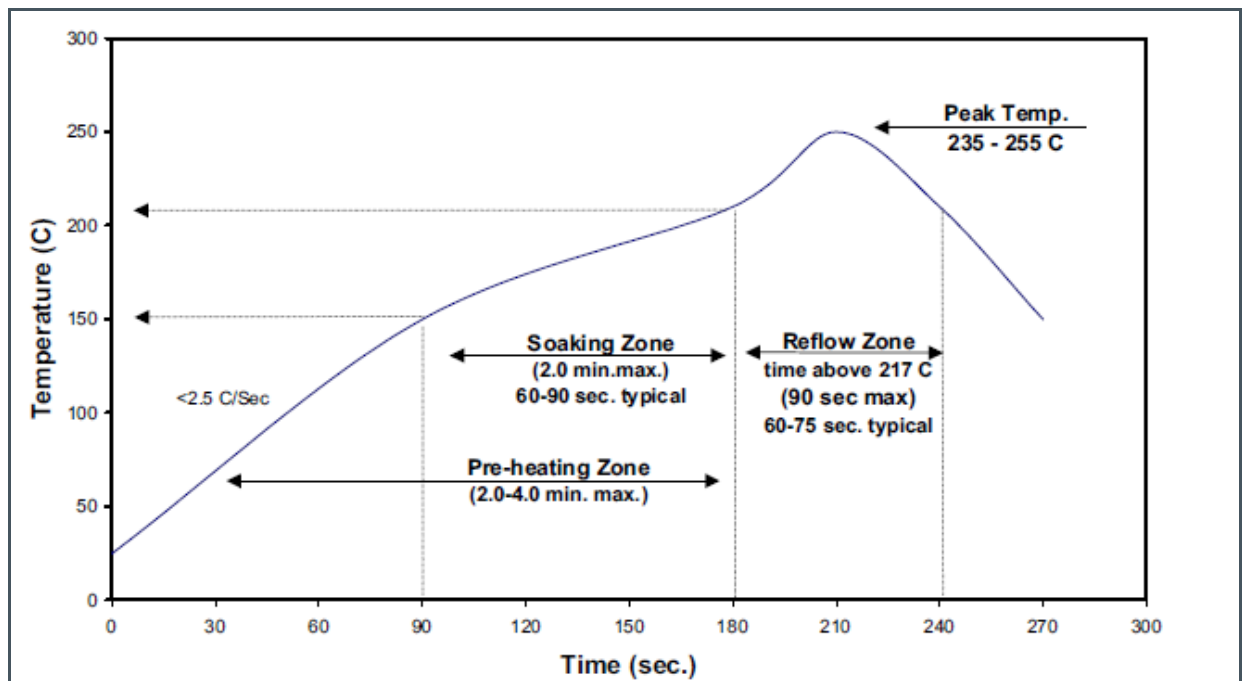

Attention

It is not advised to proceed to cleaning after SMT reflow process.

The modules **MUST NOT** be cleaned using ultrasonic cleaning.

We suggest to use flux free solder paste and not to clean after SMT.

In case a cleaning is un-avoidable, rinse with DI water, followed by a 2h bake @70°C.

11 Handling

11.1 Pick Up

Recommended pick up position on the top window (green circle), touching directly the glass.

Figure 20:
Pick Up Location

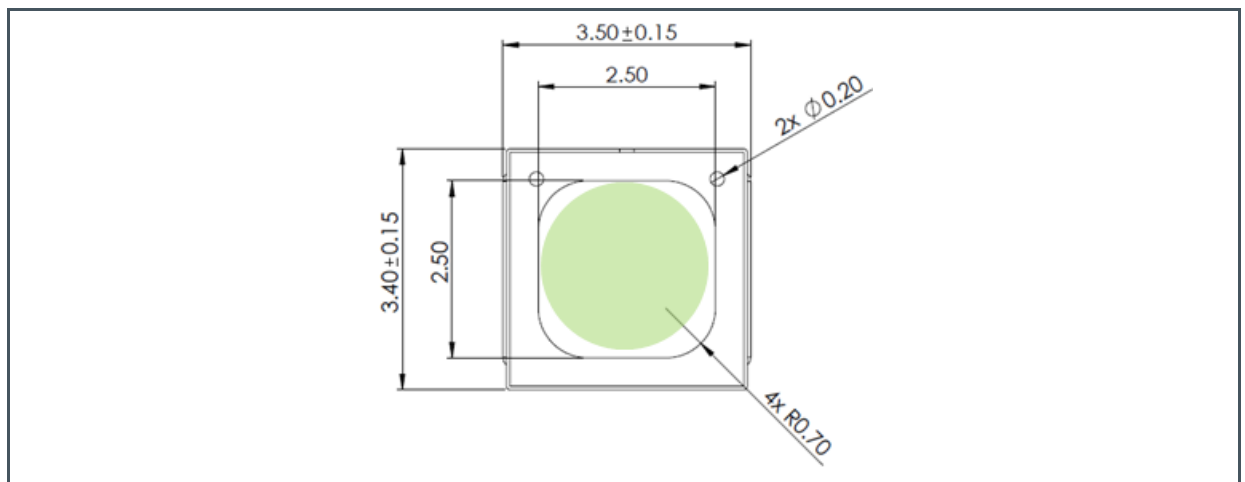

(1) Picking area within green area

12 Appendix

12.1 RoHS & REACH Compliance

The BELICE module is compliant with the European RoHS Directive 2002/95/EC (Restriction of the Use of Certain Hazardous Substances in Electrical and Electronic Equipment) and REACH (Registration, Authorization and Restriction of Chemicals, European Union Regulation (EC) 1907/2006).

12.2 Safety Advice

Depending on the operational use of the device, the modules can emit highly concentrated non-visible infrared light which can be hazardous to the human eyes. Products incorporating these modules may have to follow the safety precautions described by IEC 60825-1 and IEC 62471.

This product emits infrared radiation and has not yet been classified under IEC 60825-1. All appropriate safety precautions should be exercised in the operation and use of this product.



CAUTION

Avoid direct eye exposure except as may be determined and directed by Purchaser.
Appropriate protective eyewear should be worn when operating.
Use of magnifying optical instruments with this component may increase eye hazard.



LASER PRODUCT
LASER RADIATION – AVOID DIRECT EYE EXPOSURE
WAVELENGTH: 850nm
MAXIMUM OUTPUT POWER: Depends on drive mode
WEAR PROTECTIVE GLASSES

13 Revision Information

Document Status	Product Status	Definition
Product Preview	Pre-Development	Information in this datasheet is based on product ideas in the planning phase of development. All specifications are design goals without any warranty and are subject to change without notice
Preliminary Datasheet	Pre-Production	Information in this datasheet is based on products in the design, validation or qualification phase of development. The performance and parameters shown in this document are preliminary without any warranty and are subject to change without notice
Datasheet	Production	Information in this datasheet is based on products in ramp-up to full production or full production which conform to specifications in accordance with the terms of ams AG standard warranty as given in the General Terms of Trade
Datasheet (discontinued)	Discontinued	Information in this datasheet is based on products which conform to specifications in accordance with the terms of ams AG standard warranty as given in the General Terms of Trade, but these products have been superseded and should not be used for new designs

Changes from previous version to current revision v1-00	Page

- Page and figure numbers for the previous version may differ from page and figure numbers in the current revision.
- Correction of typographical errors is not explicitly mentioned.

14 Legal Information

Copyrights & Disclaimer

Copyright ams AG, Tobelbader Strasse 30, 8141 Premstaetten, Austria-Europe. Trademarks Registered. All rights reserved. The material herein may not be reproduced, adapted, merged, translated, stored, or used without the prior written consent of the copyright owner.

Devices sold by ams AG are covered by the warranty and patent indemnification provisions appearing in its General Terms of Trade. ams AG makes no warranty, express, statutory, implied, or by description regarding the information set forth herein. ams AG reserves the right to change specifications and prices at any time and without notice. Therefore, prior to designing this product into a system, it is necessary to check with ams AG for current information. This product is intended for use in commercial applications. Applications requiring extended temperature range, unusual environmental requirements, or high reliability applications, such as military, medical life-support or life-sustaining equipment are specifically not recommended without additional processing by ams AG for each application. This product is provided by ams AG "AS IS" and any express or implied warranties, including, but not limited to the implied warranties of merchantability and fitness for a particular purpose are disclaimed.

ams AG shall not be liable to recipient or any third party for any damages, including but not limited to personal injury, property damage, loss of profits, loss of use, interruption of business or indirect, special, incidental or consequential damages, of any kind, in connection with or arising out of the furnishing, performance or use of the technical data herein. No obligation or liability to recipient or any third party shall arise or flow out of ams AG rendering of technical or other services.

RoHS Compliant & ams Green Statement

RoHS Compliant: The term RoHS compliant means that ams AG products fully comply with current RoHS directives. Our semiconductor products do not contain any chemicals for all 6 substance categories, including the requirement that lead not exceed 0.1% by weight in homogeneous materials. Where designed to be soldered at high temperatures, RoHS compliant products are suitable for use in specified lead-free processes.

ams Green (RoHS compliant and no Sb/Br): ams Green defines that in addition to RoHS compliance, our products are free of Bromine (Br) and Antimony (Sb) based flame retardants (Br or Sb do not exceed 0.1% by weight in homogeneous material).

Important Information: The information provided in this statement represents ams AG knowledge and belief as of the date that it is provided. ams AG bases its knowledge and belief on information provided by third parties, and makes no representation or warranty as to the accuracy of such information. Efforts are underway to better integrate information from third parties. ams AG has taken and continues to take reasonable steps to provide representative and accurate information but may not have conducted destructive testing or chemical analysis on incoming materials and chemicals. ams AG and ams AG suppliers consider certain information to be proprietary, and thus CAS numbers and other limited information may not be available for release.

Headquarters

ams AG
Tobelbader Strasse 30
8141 Premstaetten
Austria, Europe
Tel: +43 (0) 3136 500 0

Please visit our website at www.ams.com

Buy our products or get free samples online at www.ams.com/Products

Technical Support is available at www.ams.com/Technical-Support

Provide feedback about this document at www.ams.com/Document-Feedback

For sales offices, distributors and representatives go to www.ams.com/Contact

For further information and requests, e-mail us at ams_sales@ams.com