

11-Channel Spectral Color Sensor

www.ams.com



AS7341 – 11-Channel Spectral Color Sensor

- Color matching and skin tone measurement
- Enhanced Artificial Intelligence: Search & shop by color (eCommerce boost)
- Optional: Flicker immune camera operation and image optimization (AWB automatic white balancing)
- Mobile phone compatible package

PRELIMINARY INFORMATION

Sensing
is life.

General Description

ams, X-Rite and PANTONE® presents a joint solution to bring accurate color matching directly to smartphones in order to improve retail and ecommerce applications, artificial intelligence and other tools help consumers find the right products.

Research shows that consumers lack confidence in purchasing color-critical items online. This uncertainty is typically due to past experiences which did not meet expectations and a difficulty in communicating color from home to store. Consumers wrongly expect to be able to simply take a photo of the inspiration color with their smartphones and match it to a desired item. However, the wide variety of tones and colors available in home décor, apparel and cosmetics is difficult to accurately reproduce on mobile device displays. Cameras are not precise enough to accurately compare the color between an online product offering and how it will appear in the

consumer's intended physical environment. This makes online color-critical purchase decisions unreliable and limits consumer confidence.

The joint ams and X-Rite solution is the world's first spectral color measurement solution utilizing Pantone Color Standards to be embedded in a mobile device. The miniaturized module is intended for integration in the backside of a smartphone. The module contains an advanced 11-channel spectral sensor and optical components that enable users to measure color of objects in a non-contact manner. The solution will connect to Pantone's world-leading color reference systems using cloud technology. Consumers, brands and retailers will now be able to identify and share product colors, making it easier to search product catalogs and select color-critical items with confidence.

Features	Benefits	Applications
<ul style="list-style-type: none"> - 8 optical channels distributed over the visible range - 3 extra channels: Clear, Flicker and NIR channel - 6 parallel ADCs for signal processing - Ultra-low-profile package 3.1 x 2 x 1mm 	<ul style="list-style-type: none"> - Spectral information enables highly accurate object color measurements - Detection & rejection environmental influences such as light sources - Optimized channel count and signal processing for fast measurements - Mobile phone compatible package 	<ul style="list-style-type: none"> - Color matching and skin tone measurement - Enhanced Artificial Intelligence: Search & shop by color (eCommerce boost) - Optional: Flicker immune camera operation and image optimization (AWB automatic white balancing)

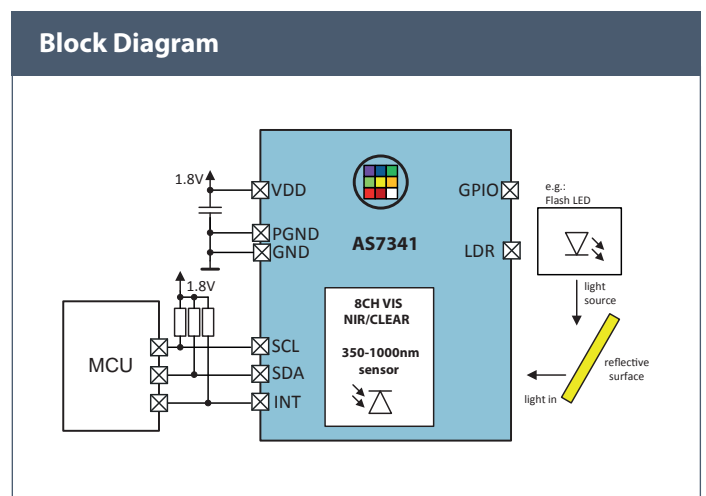
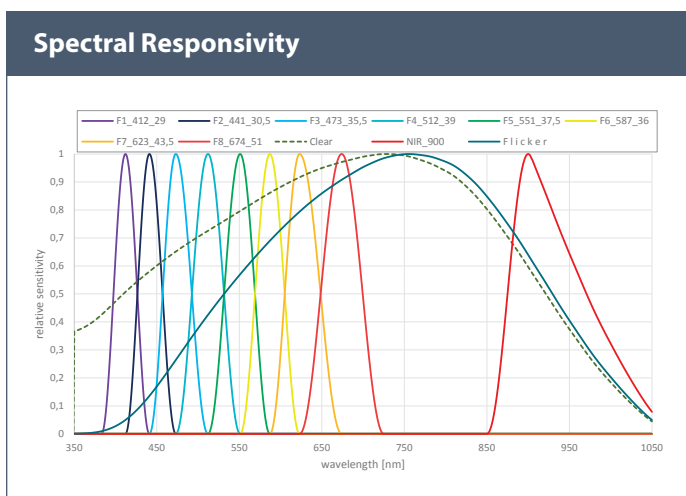

PRODUCT IN DEVELOPMENT

Kevin Jensen
 Senior Marketing Manager
 ams Sensor Germany GmbH
 Göschwitzer Straße 32, 07745 Jena, Germany
 Phone +49 3641 2809-9911
 kevin.jensen@ams.com

www.ams.com
 products@ams.com
 © 02/2018 by ams
 Subject to change without notice

Headquarters
 ams AG
 Tobelbader Strasse 30, 8141 Premstaetten, Austria
 Phone +43 3136 500-0