



## Application Note

AN000325

# AS62xx - Thermal Design Guideline

## PCB Reference Design

v3-00 • 2019-Oct-22

---

# Content Guide

<b>1</b>	<b>Introduction.....</b>	<b>3</b>	<b>3</b>	<b>Thermal Load vs. Temperature</b>	
1.1	Ordering Information .....	3		<b>Response Time .....</b>	<b>6</b>
<b>2</b>	<b>Temperature Sensing of</b>		3.1	Reduce Thermal Load with PCB Cutouts .....	6
	<b>Components on PCB.....</b>	<b>4</b>	3.2	Flex PCB .....	7
2.1	Temperature Sensing on Same PCB Layer		<b>4</b>	<b>Revision Information.....</b>	<b>8</b>
	Side .....	4	<b>5</b>	<b>Legal Information .....</b>	<b>9</b>
2.2	Temperature Sensing on the Opposite PCB				
	Layer Side .....	5			

# 1 Introduction

The AS62xx device family is a digital temperature sensor family for applications that require small form factors, ultra-low power consumption and high accuracy.

Temperature monitoring could be challenging and with this document, some design guidelines are listed to support you in your product design.

## 1.1 Ordering Information

Ordering Code	Package	Marking	Delivery Form	Delivery Quantity
AS6212-AWLT-S	WLCSP	AS6212	Tape & Reel	500 pcs/reel
AS6212-AWLT-L	WLCSP	AS6212	Tape & Reel	5000 pcs/reel
AS6214-AWLT-S	WLCSP	AS6214	Tape & Reel	500 pcs/reel
AS6214-AWLT-L	WLCSP	AS6214	Tape & Reel	5000 pcs/reel
AS6218-AWLT-S	WLCSP	AS6218	Tape & Reel	500 pcs/reel
AS6218-AWLT-L	WLCSP	AS6218	Tape & Reel	5000 pcs/reel
AS6204-AWLM-S	WLCSP	AS6204	Tape & Reel	500 pcs/reel
AS6204-AWLT-L	WLCSP	AS6204	Tape & Reel	5000 pcs/reel
AS6200C-AWLM-S	WLCSP	AS6MCC	Tape & Reel	500 pcs/reel
AS6200C-AWLT-L	WLCSP	AS6MCC	Tape & Reel	5000 pcs/reel
AS6200-AWLT-S	WLCSP	AS6200	Tape & Reel	500 pcs/reel
AS6200-AWLT-L	WLCSP	AS6200	Tape & Reel	5000 pcs/reel

## 2 Temperature Sensing of Components on PCB

### 2.1 Temperature Sensing on Same PCB Layer Side

In order to get a good sensing results the AS62xx should be placed as near as possible to the component you want to sense. Connect the common GND plane as close as possible together as shown in Figure 1

Keep other copper layers and vias away from sensor to minimize the thermal load.

**Figure 1 :**  
**Copper Connection on Same Layer for Heat Transfer**

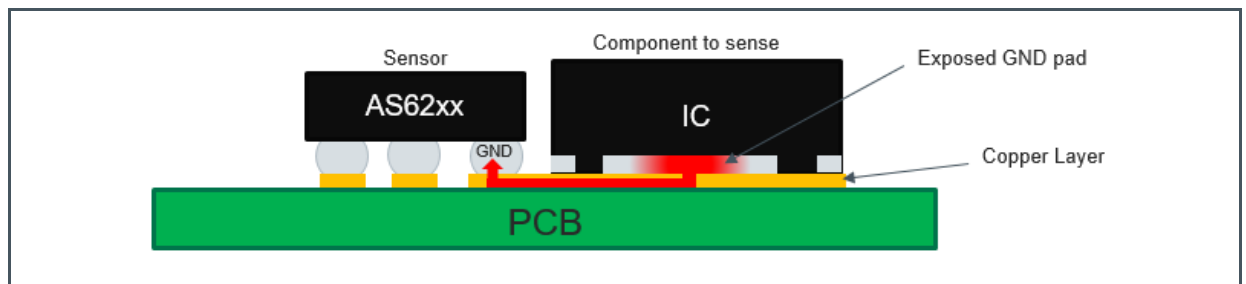

The advantage of same side measuring is that to keep influence of other heat sources of the bottom side away from the sensor.

## 2.2 Temperature Sensing on the Opposite PCB Layer Side

Thermal vias can be used in case the sensing component is on the bottom side as shown in Figure 2. In order to reduce thermal load make sure there are no copper layers between sensor and the component you want to sense.

**Figure 2 :**  
Temperature Sensing over Thermal Via

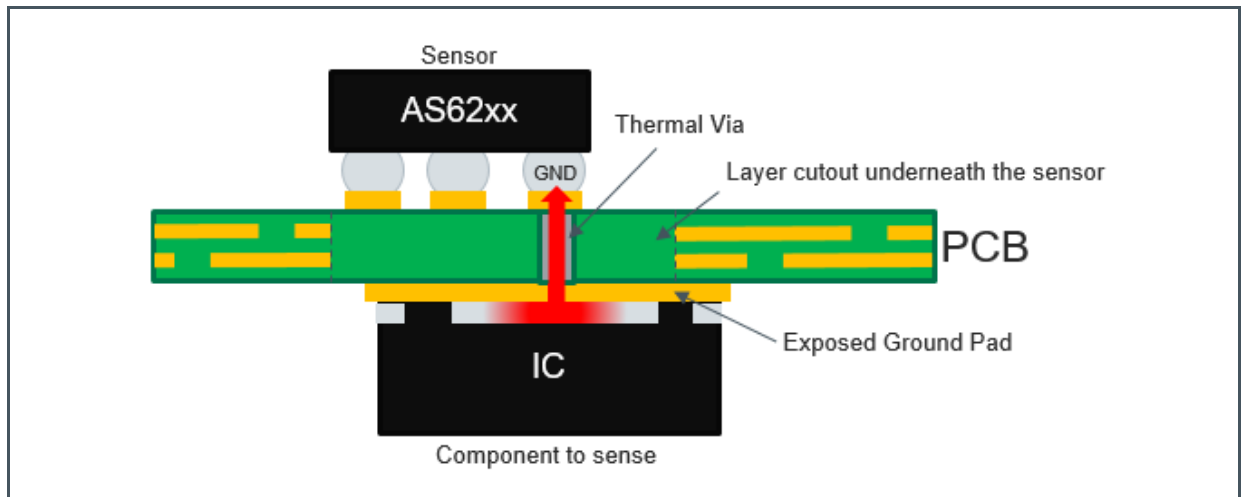

## 3 Thermal Load vs. Temperature Response Time

### 3.1 Reduce Thermal Load with PCB Cutouts

#### 3.1.1 Cutout through PCB

To further improve the response time of the sensor, it is recommended to reduce the thermal capacity of the PCB. One important measure is to keep the area around the sensor free of any copper planes. In addition to that, a cutout as can be seen in Figure 3 should be applied.

Figure 3 :  
PCB Cutout

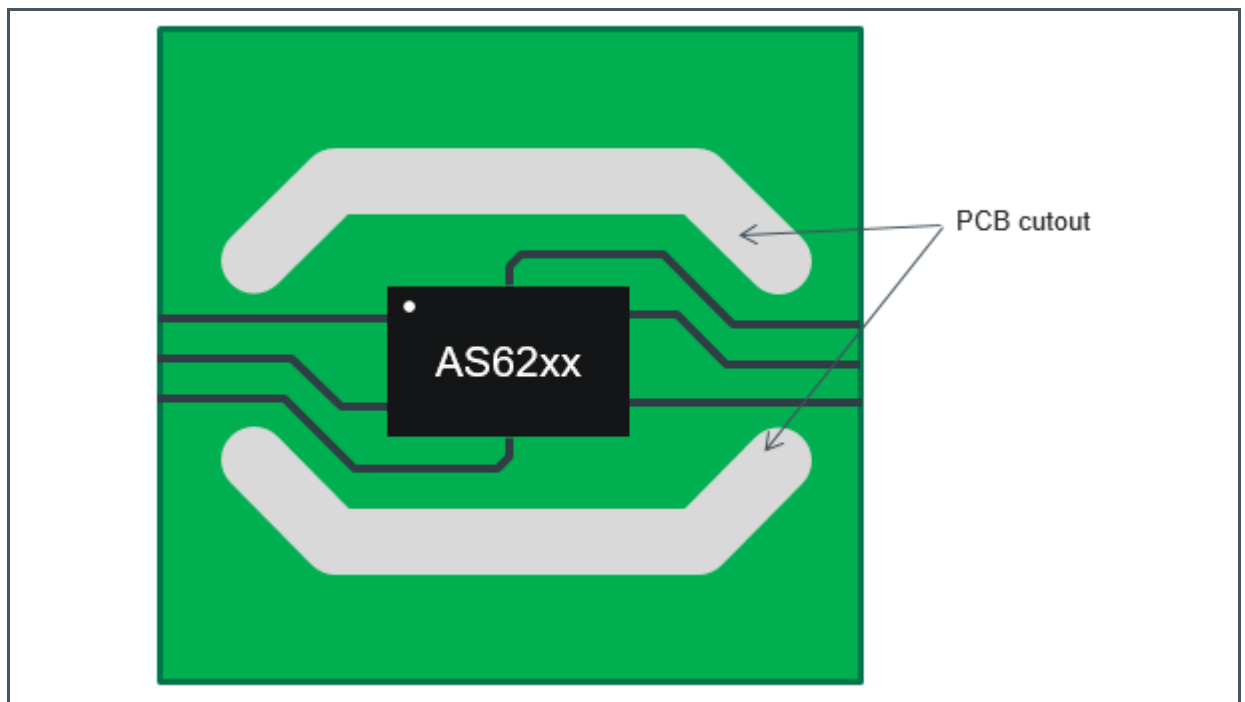

### 3.1.2 PCB Cutout Area

In addition, to reduce thermal load of the PCB the bottom side can be cut out as shown in Figure 4

Figure 4 :  
PCB Cutout Bottom Side

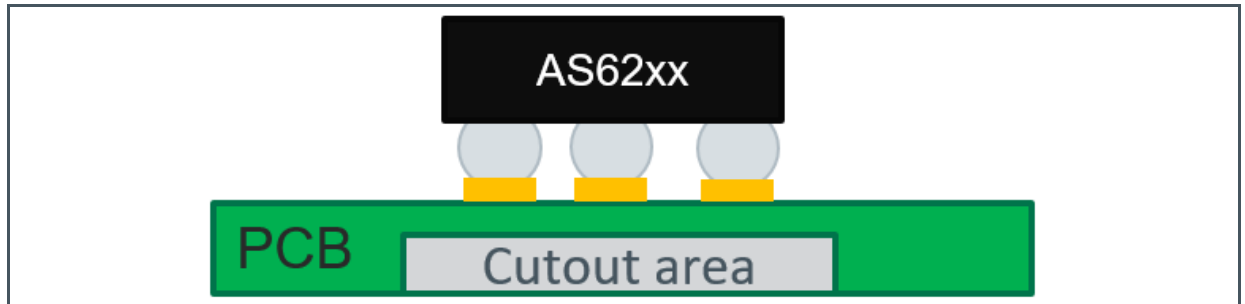

### 3.2 Flex PCB

Another possibility to reduce thermal load is the use of a rigid flex PCB. In the Figure 5 is an application example how it can be done to measure the housing temperature. A thermal tape or adhesive can be used to fix the rigid flex to the case. The exposed pad increases the thermal conduction. In best case, use a thermal via to connect the sensor ground.

Figure 5 :  
Sensor on Rigid Flex PCB

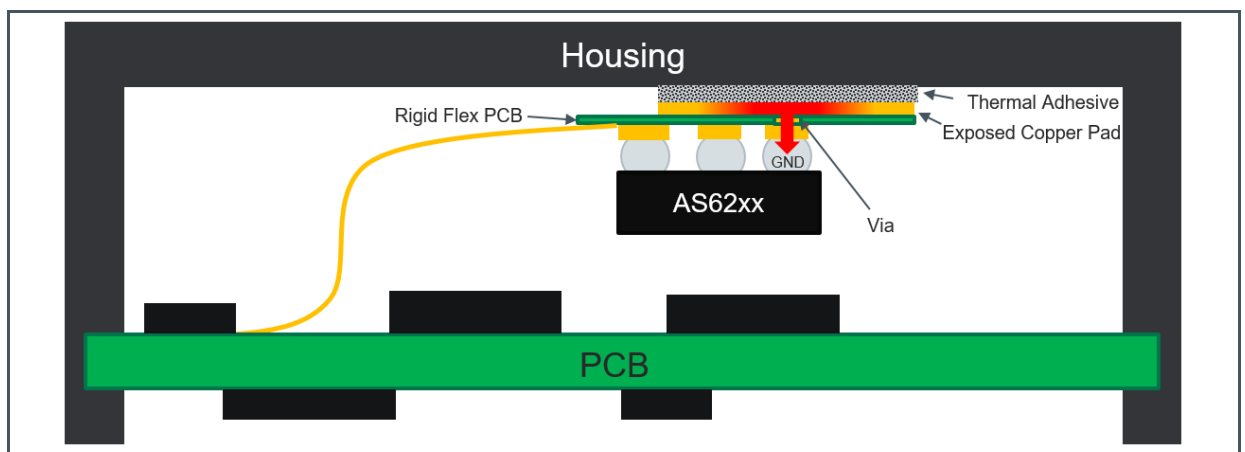

# 4 Revision Information

Changes from previous version to current revision v3-00	Page
Updated the document format	
Renamed AS62x0 to AS62xx	
Updated Ordering Information table with AS6212, AS6214, AS6218	

- Page and figure numbers for the previous version may differ from page and figure numbers in the current revision.
- Correction of typographical errors is not explicitly mentioned.



## 5 Legal Information

### Copyrights & Disclaimer

Copyright ams AG, Tobelbader Strasse 30, 8141 Premstaetten, Austria-Europe. Trademarks Registered. All rights reserved. The material herein may not be reproduced, adapted, merged, translated, stored, or used without the prior written consent of the copyright owner.

Information in this document is believed to be accurate and reliable. However, ams AG does not give any representations or warranties, expressed or implied, as to the accuracy or completeness of such information and shall have no liability for the consequences of use of such information.

Applications that are described herein are for illustrative purposes only. ams AG makes no representation or warranty that such applications will be appropriate for the specified use without further testing or modification. ams AG takes no responsibility for the design, operation and testing of the applications and end-products as well as assistance with the applications or end-product designs when using ams AG products. ams AG is not liable for the suitability and fit of ams AG products in applications and end-products planned.

ams AG shall not be liable to recipient or any third party for any damages, including but not limited to personal injury, property damage, loss of profits, loss of use, interruption of business or indirect, special, incidental or consequential damages, of any kind, in connection with or arising out of the furnishing, performance or use of the technical data or applications described herein. No obligation or liability to recipient or any third party shall arise or flow out of ams AG rendering of technical or other services.

ams AG reserves the right to change information in this document at any time and without notice.

### RoHS Compliant & ams Green Statement

**RoHS Compliant:** The term RoHS compliant means that ams AG products fully comply with current RoHS directives. Our semiconductor products do not contain any chemicals for all 6 substance categories, including the requirement that lead not exceed 0.1% by weight in homogeneous materials. Where designed to be soldered at high temperatures, RoHS compliant products are suitable for use in specified lead-free processes.

**ams Green (RoHS compliant and no Sb/Br):** ams Green defines that in addition to RoHS compliance, our products are free of Bromine (Br) and Antimony (Sb) based flame retardants (Br or Sb do not exceed 0.1% by weight in homogeneous material).

**Important Information:** The information provided in this statement represents ams AG knowledge and belief as of the date that it is provided. ams AG bases its knowledge and belief on information provided by third parties, and makes no representation or warranty as to the accuracy of such information. Efforts are underway to better integrate information from third parties. ams AG has taken and continues to take reasonable steps to provide representative and accurate information but may not have conducted destructive testing or chemical analysis on incoming materials and chemicals. ams AG and ams AG suppliers consider certain information to be proprietary, and thus CAS numbers and other limited information may not be available for release.

### Headquarters

ams AG  
Tobelbader Strasse 30  
8141 Premstaetten  
Austria, Europe  
Tel: +43 (0) 3136 500 0

Please visit our website at [www.ams.com](http://www.ams.com)

Buy our products or get free samples online at [www.ams.com/Products](http://www.ams.com/Products)

Technical Support is available at [www.ams.com/Technical-Support](http://www.ams.com/Technical-Support)

Provide feedback about this document at [www.ams.com/Document-Feedback](http://www.ams.com/Document-Feedback)

For sales offices, distributors and representatives go to [www.ams.com/Contact](http://www.ams.com/Contact)

For further information and requests, e-mail us at [ams\\_sales@ams.com](mailto:ams_sales@ams.com)