

## Data-rich 3.5mm jack vies with USB-C for headsets

By Horst Gether, ams AG

The 3.5mm phone jack is a well-established standard in the audio industry. Originally invented back in the 19<sup>th</sup> century for telephone switch boards, it made its way into mobile phones, tablets and personal computers to connect audio and communication headsets for phone calls or simply for listening to music. While the phone jack has a rather long evolutionary history, the functionality that the 3.5mm four-pole accessory device provides to its end customers is rather limited.

Figure 1: 3.5mm phone jack mobile phone architecture

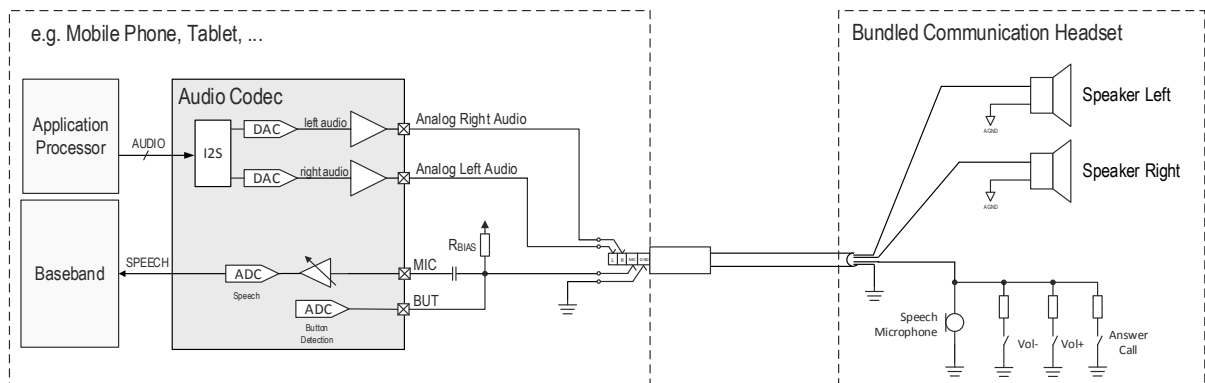

A simplified block diagram of an existing 3.5mm audio jack implementation is shown in

Figure 1. The diagram shows the standard 3.5mm audio jack that is connected to the audio codec inside the mobile phone. To support speech transmission for phone calls there is the MIC and BUT input, where the fourth pole of the audio jack is connected. This signal line has an analog microphone connected, and in parallel, one to three push buttons each with a series resistor. If a button is pressed, the serial resistor defines, with the bias resistor RBIAS inside the phone, a voltage drop that can be measured by the Button Detection ADC to accept a phone call or simply change music playback volume. If no button is pressed, the microphone is active and the captured speech signal is digitized by the speech ADC inside the audio codec and then fed into the baseband.

The architecture shown in

Figure 1 hasn't changed during the last couple of years, despite how rapidly mobile phones are evolving. Based on the possibilities mobile phones offer nowadays in terms of computation power, the functionality that 3.5mm audio jack accessories can provide is rather limited. One reason for this might be that headsets are very cost-optimized and need to be compliant with each other. Thus there is a continuous pull from the market to enhance the functionality of the 3.5mm audio jack while keeping the cost at a minimum. One particular application requested by many vendors is the support of Active Noise Cancellation (ANC) without the need of a battery inside the accessory. This function was only possible with a battery inside the accessory and an analog or digital ANC device inside the headset, as shown in

Figure 3. An alternative solution, which eliminates the need for the battery, makes use of the USB interface to get power out of the mobile phone (as shown in

Figure 2).

Figure 2: USB-based Transmit and Receive path Noise Cancelling headset

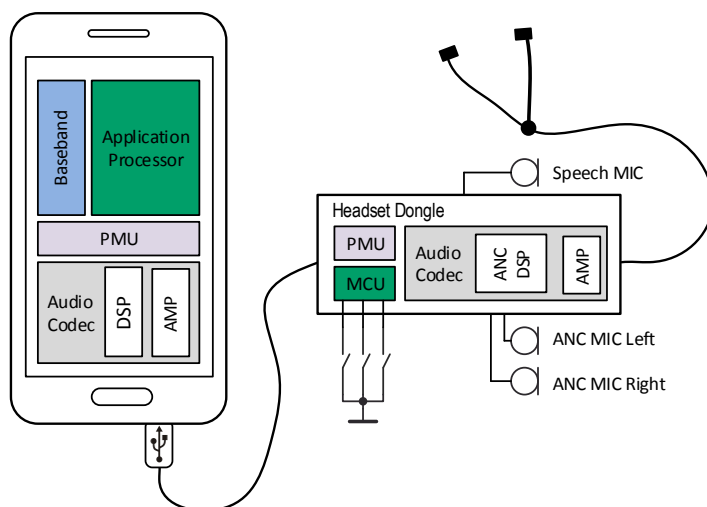

Both options are technically feasible but not ideal in terms of cost and solution size, since the driving factors for bundling an ANC headset, for example, are low cost and small form factor. Since there is

a lot of redundancy inside the mobile phone and the accessory (Audio Codec, DSP extension, Amplifier, PMU), this is not beneficial for the overall aim to achieve low system cost and enable more functionality.

Figure 3: 3.5mm audio jack-based Transmit and Receive path Noise Cancelling Headset with battery.

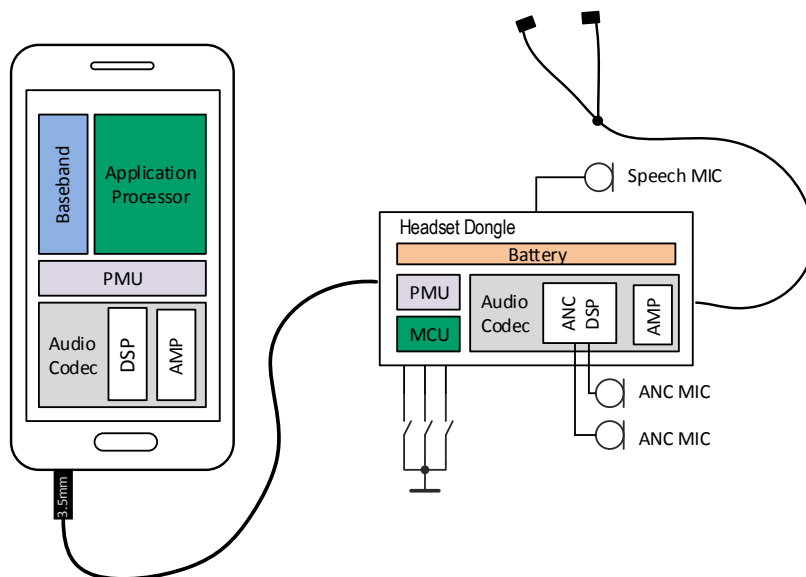

**How ACI allows for lowest system cost and smaller form factor**

In order to address this issue and listen to the needs of customers, ams AG invented a new interface standard to be used with the 3.5mm audio jack, offering full backward compatibility to existing legacy headsets and mobile phones. The new interface technology, called Accessory Communication Interface (ACI), utilizes the microphone signal line out of the four audio jack contacts to enhance the functionality of this well-established connector, and turn it into a digital bidirectional interface.

Figure 4: USB-C and 3.5mm audio jack ANC headset powered by ACI technology

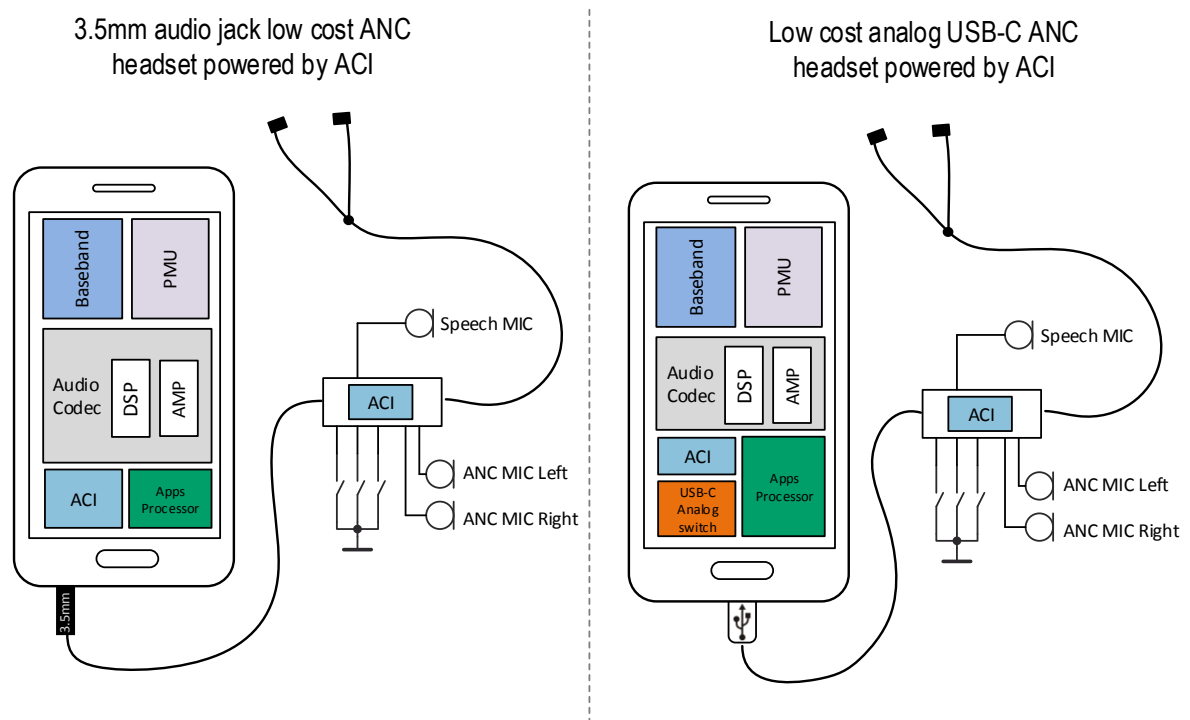

Furthermore, the focus has been put on lowest system cost, with the strategy to reuse the computation power inside the mobile phone rather than having redundant blocks inside the phone and the accessory.

Figure 4 shows the implementation structure of an ACI system for a 3.5mm audio jack system and an analog USB-C based system. Since the new USB-C standard supports analog audio output, by just adding a simple analog switch inside the mobile phone, it is also possible to make use of the ACI technology over the USB-C connector and its microphone wire to enable low-cost ANC headsets. All you need for both options is an ACI master inside the mobile phone. This master device can certainly, midterm, be part of the audio codec, which further reduces system cost.

On the accessory side all the blocks like audio codec, headphone amplifier, MCU and additional power management are no longer necessary with the ACI system. All the buttons for user interface control and the microphones for speech and Active Noise Cancelling are directly connected to the ACI-Slave chip inside the accessory. The approach is to simply collect all sensor, microphone and button information and transfer it to the host. The audio signal processing is handled by the audio codecs Digital Signal Processor (DSP) for Transmit Path Noise Reduction, as well as Receive Path Noise reduction like is the case if there is no headset connected. All relevant sensor and button information is transferred via I2C and interrupts to the application processor to enable/disable various functions of the accessory.

### **ACI's advanced capabilities**

A more detailed system block diagram of the ACI solution with all relevant connections is shown in

Figure 5. One of the design goals for ACI was minimum latency, in order to allow for Rx path noise reduction. Therefore the ACI system can feature as little as  $1.1\mu\text{s}$  latency for each microphone channel. This is a major advantage of the ACI system over the digital USB-C implementation, since it does not support such low latency in order to reuse the audio codec inside the mobile phone for Rx noise reduction. For simple integration into a mobile phone or tablet the device has a clock input to make sure the digital microphone data (up to 5 channels) are synchronous to the audio codec for digital signal processing.

Figure 5: ACI System Overview – Block Diagram

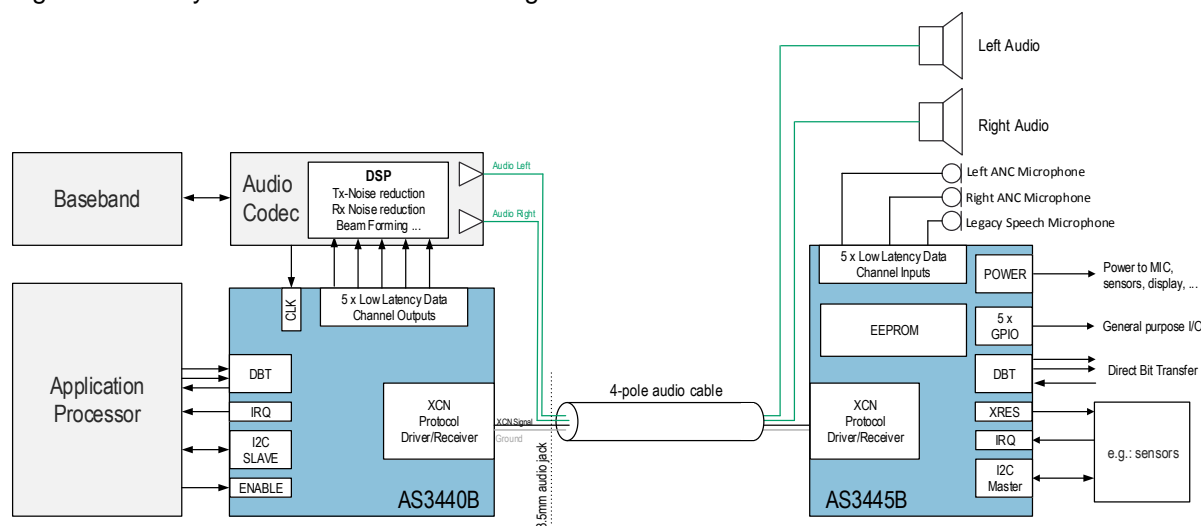

In order to get rid of the battery inside an accessory the system supports power extraction on the slave side and with output currents up to 100mA. This supply voltage (1.4 – 1.9V) can be used to power microphones or additional sensors that are connected to the I2C master of AS3445B. Since the ACI protocol transfers besides IRQs from slave to master also I2C information it is possible that the application processor directly reads out sensor data of sensors that are connected to the I2C master of the AS3445B. In order to maintain the highest reliability for the so-called meta-data transfer (I2C, IRQ, Direct Bit Transfer), this data is also protected with CRC to avoid wrong data transmission. An EEPROM inside the AS3445B is used to store application-specific information like pre-amplifier gain settings of the microphone inputs or GPIO configuration to define the accessory hardware. The rest of the EEPROM is available for general purpose use. Thus, it is possible to program production data, serial number, etc. to the system, or allow the customer to put user-specific data to the accessory, such as a name or personalized EQ settings for preferred music playback settings. All this functionality and much more is implemented by just using the microphone wire for the complete communication and power transfer to the AS3445B, as shown in

Figure 5. The analog audio signals that are operated by the audio codec are not influenced by the ACI communication running on the microphone wire.

**How does this tricky ACI thing work?**

The communication between master and slave is based on a half-duplex time multiplexed modulation scheme.

Figure 6: MIC Wire – Modulation Scheme

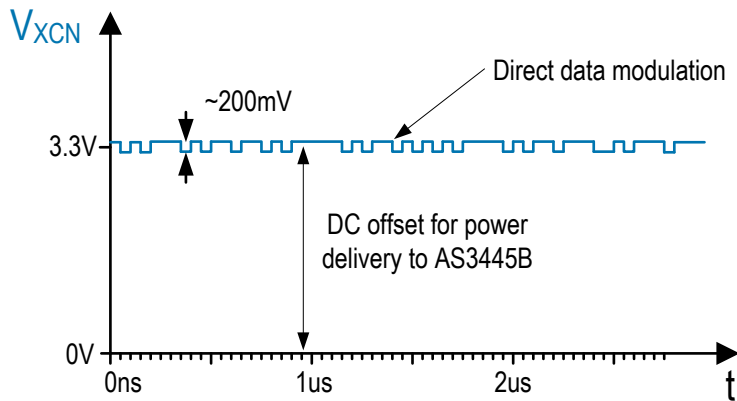

There is a DC offset of typically 3.3V present on the signal line in order to provide power to the AS3445B. The microphone data as well as the metadata is then directly modulated to the 3.3V supply voltage. Since the focus of the interface is on low latency, 83% of the overall bandwidth is used for this purpose to transfer low latency data (typ. microphone data). Another 10% is used to synchronize the clocks between master and slave, and the last 7% provides the metadata transfer for I2C communication to AS3445B, direct bit transfer and interrupts.

Since the ACI system allows for audio cable lengths from 0m to 1m, which is implemented in a self-calibrating manner with no need to change settings dependent on cable length, it is important to maintain signal integrity of the transferred data on the signal line. Therefore the communication channel needs to be well-defined, as is shown in the block diagram in

Figure 7. The XCN pin on both devices needs a termination resistor of  $21\Omega$  to avoid reflections of the transferred data due to the long signal line. The microphone cable needs to be compliant to this resistance with a characteristic impedance of  $21\Omega$  and a tolerance of  $\pm 20\%$ .

Figure 7: MIC wire data modulation

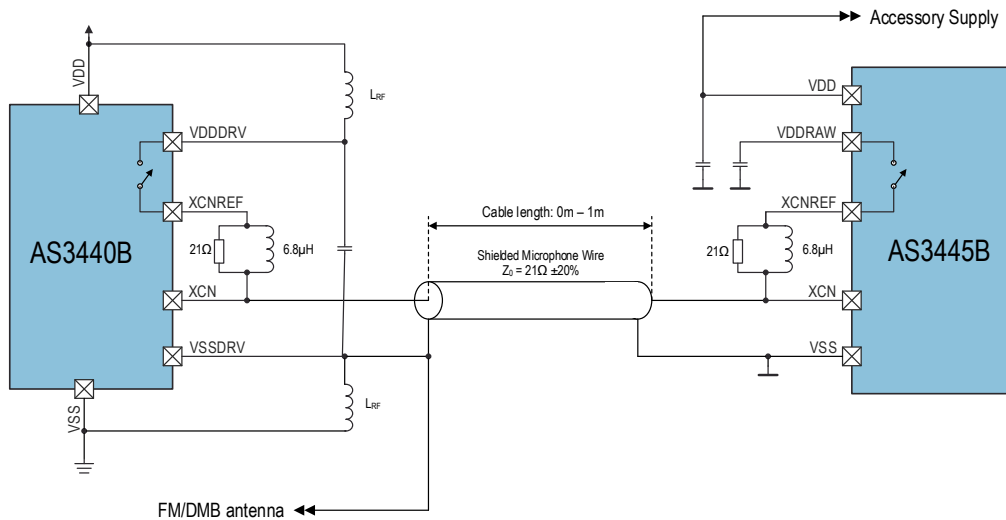

### Alternative ACI use cases

In addition to offering low-cost and the smallest form factor ANC headsets for bundling with a mobile phone, ACI technology can also be used to solve problems like mechanical constraints in a system due to limited space. One possible option would be interconnection of two printed circuit boards (PCBs). Usually there are multi-pole connectors used to connect PCBs and very often the number of poles available is limited, thus the design engineer cannot feed all sensor signals back to the main PCB. The ACI system could potentially be used to replace a multi-pole connector with a two-pole connector and feed back up to 5 microphone channels, multiple buttons as well as I2C sensor data. Even longer cable connections up to 1 meter are not an issue to transfer I2C sensor data due to the architecture of the interface.



Figure 8: Alternative Application Example – Headset ear-cup interconnect

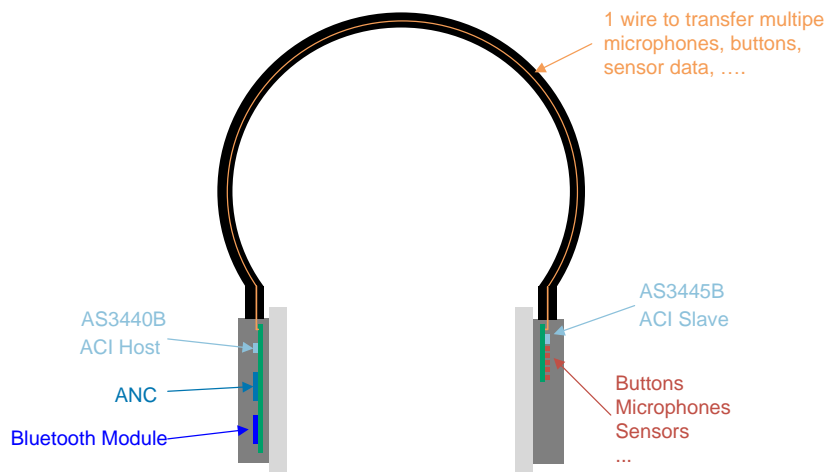

A second and more application-specific use case that also solves a mechanical problem in the headset industry is shown in

Figure 8. Usually there are many interconnections between left and right ear cups, and the number of available cables is limited due to mechanical constraints. In such a case, ACI could be used with a single additional wire to connect multiple microphones, buttons and sensors located on the second ear cup to the main PCB on the left ear cup, where the main processor of the headset is located. [www.ams.com](http://www.ams.com)

For more information, AS3440B please visit.

**For further information**

ams AG  
Horst Gether



Product Manager Active Noise Cancellation

Tel: +43 (0) 3136 500 31210

[horst.gether@ams.com](mailto:horst.gether@ams.com)

[www.sensors@ams.com](http://www.sensors@ams.com)

[www.ams.com](http://www.ams.com)